

Contents

Page	
2	Introduction
3	Components
4	Features
5	Downloading
6	Uploading
7	Installation S6-GPS Control Panel (S6 & S6-R)
12	Installation S6-RLD (S6-R only)
16	Starting up
16	Standby screen
17	City Mode Button
18	Cancel Button
18	Menu Button
18	Alert patterns
20	Saving New Co-ordinates
20	Alert Settings
21	RLD Settings
23	Automute
22	Speed Limit Alert
23	Speed Measurement Type
24	Vehicle Speed
24	Camera Detection Settings
26	Atomic Clock
26	Backlight/Visual Alert
26	Compass
27	Satellite Counter
28	Volume
28	Adding & Deleting New Locations
28	Dial-Up Numbers
29	Motorcycle Installation
30	Troubleshooting
31	Specifications
32	Accessories & Price List
33	Service under Warranty
34	Registering your Snooper S6 or S6-R neo

IMPORTANT

You must register your S6 or S6-R before use. It will not be possible to perform downloads until registration has been completed. See 'Registering your S6 or S6-R' for further details

Introduction

Congratulations on buying a Snooper Safety Alert System.

This user manual aims to provide you with installation and user instructions for both the S6 and S6-R NEO GPS and radar/laser location devices.

Utilising the very latest Global Positioning Satellite (GPS) and radar/laser technology, Snooper have created the S6 and S6-R NEO which have been specially designed to help you drive safely within the confines of today's speed limits, by alerting you quickly and easily to the presence of Police speed traps, often located at Accident Blackspots, electronically indicating potentially dangerous and hazardous situations.

The geographical co-ordinates of all 'fixed' speed monitoring systems and many officially designated accident 'hotspots' have been stored on a database that is constantly monitored and up-dated by our data collection team ensuring that you are alerted to every potentially hazardous stretch of road or danger spot. The S6 and S6-R come complete with a highly innovative built-in modem so that you can simply plug the device into any compatible telephone socket and download the database in a matter of minutes. Your S6 or S6-R then compares your position using the GPS antenna included, with the position of every known 'fixed' speed monitoring system and accident 'hotspot' alerting you both audibly and visually via a speaker and LCD display ensuring your highest concentration at all times.

The S6-R also comes with a radar/laser detector (RLD) as standard which has been designed to detect all types of radar and laser speed monitoring systems often used in danger spots where 'Fixed' systems cannot be easily utilised, thus ensuring that you will be made alert to each and every speed monitoring system and accident hotspot whether Fixed or Mobile.

Drive Safely with Snooper!

The Snooper S6-R and S6-GPS systems have been designed and manufactured to help enhance road safety and are in no way a license to speed nor have they been designed as a substitute for concentration. Driving within the speed limit whilst carefully observing current road conditions is essential.

Components

S6 NEO

The following components come as standard with your Snooper S6 NEO:-

- 1 x S6 GPS Full Logic Control panel
- 1 x Remote Extension GPS antenna
- 1 x Windscreen suction cup bracket
- 1 x Console/dashboard mounting bracket
- 2 x Hook & loop fasteners
- 1 x Coiled power lead with cigarette lighter socket adaptor
- 1 x 2m Straight hard wire lead
- 1 x Telephone socket connection cable
- 1 x 240v power supply
- 1 x Nut & bolt pack

S6-R NEO

The Snooper S6-R NEO comes complete with all the same components incorporated in the standard S6 NEO listed above plus includes an S6-RLD radar/laser detector as standard. The following components come as standard with the S6-RLD:-

- 1 x Remote extension radar/laser detector
- 1 x Windscreen suction cup bracket
- 1 x Under bonnet mounting bracket
- 1 x Nut & bolt pack
- 1 x Hook & loop fastener



Features

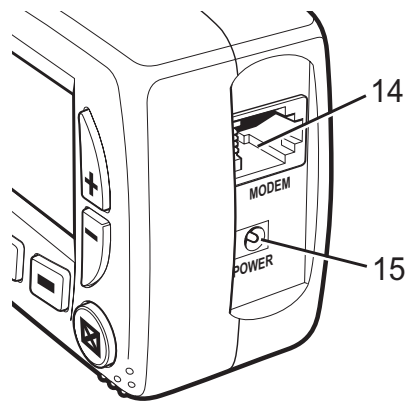
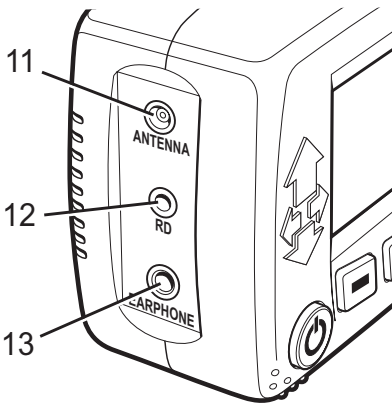
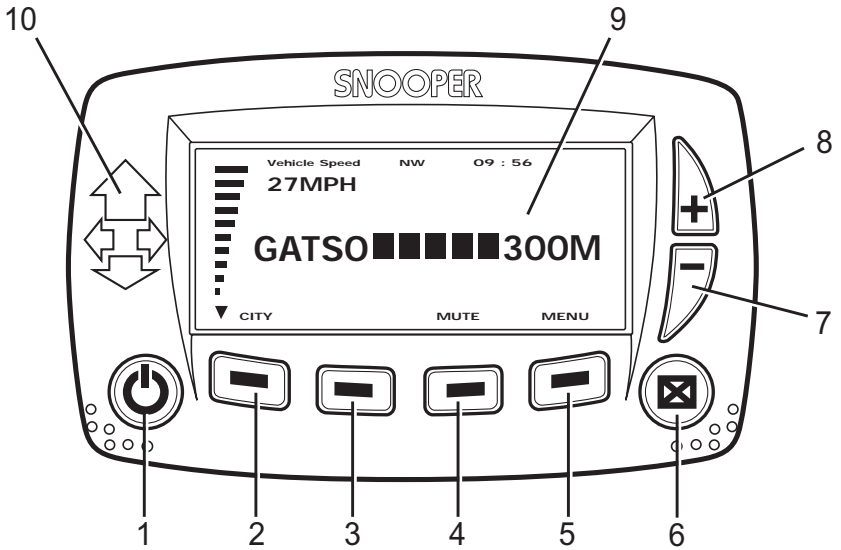

- 1 On/Off Power Button
- 2 Full Logic Button
- 3 Full Logic Button
- 4 Full Logic Button
- 5 Full Logic Button
- 6 Store 'New Location' Button
- 7 Press & Hold to Reduce Volume
- 8 Press & Hold to Increase Volume
- 9 LCD Display
- 10 Directional LED Indicator Display
- 11 GPS Extension Antenna Socket
- 12 RLD Antenna Input Socket
- 13 Earphone Socket (Earphone not inc)
- 14 Telephone Connection Socket
- 15 12v Power Input Socket

Downloading

Your Snooper S6 GPS control panel comes 'unpopulated' so before use you will need to download all the location co-ordinates on our database through the S6's built-in modem via a local rate number stored in the units memory.

Performing a download is simple. Firstly connect the 240v power supply to the power input socket on your S6 control panel, plugging the transformer into a suitable household 240v socket. Next plug end (A) of the telephone socket connection cable into the telephone socket of your S6 and end (B) into a suitable wall telephone socket as indicated below.

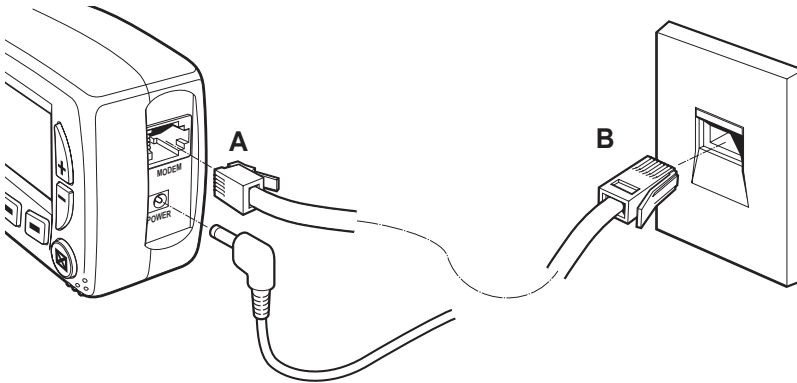

To turn the unit on press the power button (1), the LCD will briefly display 'Snooper' and will then go automatically to the standby display. Now press the MENU button (2) and then using the arrow buttons (3 or 4) follow the instructions on the screen and scroll through the options until the display reads 'DOWNLOAD' and press the 'SELECT' button (5). The screen will then read 'DOWNLOAD NOW?', to proceed press the 'SELECT' button (3).

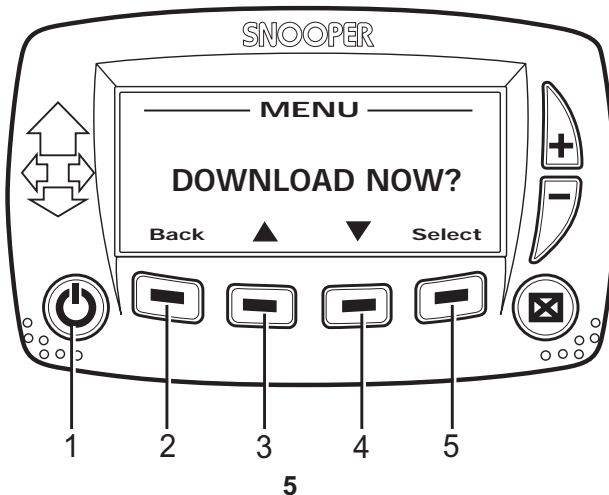

Your Snooper S6 will then automatically dial and connect to our database and once your unit has been authenticated will download the location co-ordinates. Your S6 should in most cases connect first time and an average download should be completed in just a few minutes. In the unlikely event that the connection is not achieved instantly your S6 will re-dial up to five times. If the device has tried to connect five times without success please dial the helpline number then shown on the display or see the 'Troubleshooting' section of this manual.

As there are constant additions to our location database you will need to perform regular downloads. The frequency with which you do this is entirely up to you, but we recommend that higher mileage drivers often driving on unfamiliar roads, download once or twice a week whereas lower mileage drivers perform a download once or twice a month.

Uploading

The Snooper S6-R also gives you the opportunity to 'Up load' co-ordinates if in the unlikely event you should discover a Safety Camera location not already in our database (See Operating Instructions on how to save a new location). The upload facility should be performed directly after a successful download when the display will read 'Download success' and ask the question 'Upload new co-ordinates?' If you are sure that the co-ordinates you have saved are correct press 'Yes' and they will be uploaded automatically to be verified by our data collection team. If verification proves to be positive the co-ordinates will then be added to our master database.

Installation

Once you have performed a download it is time to install the Snooper S6 into your vehicle. The most important aspects of this installation are ensuring that the GPS antenna is positioned with a clear view of the sky and that the GPS control panel is situated so that it does not interfere with the vehicles controls and does not jeopardise either the passengers or drivers safety.

Installing the GPS Extension Antenna

For best results mount the GPS antenna on either the vehicles dashboard or the rear parcel shelf. Some vehicles including Renault's, Citroens and Peugeot's may come with a 'Heat reflective', 'Comfort' or 'Metal Oxide' front windscreen which may effect the performance of the GPS antenna. In these situations the antenna should always be positioned on the rear parcel shelf. In both cases the antenna should be positioned so that it has a clear view of the sky directly above.

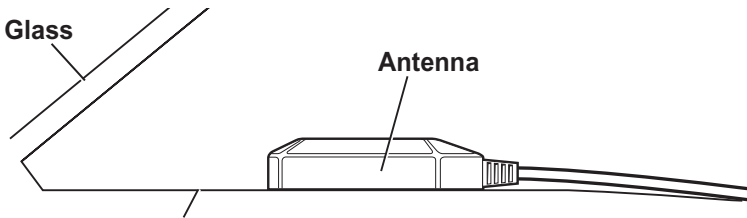

Dashboard or Parcel Shelf

Secure the antenna in place with the 'Hook and loop' fastener provided and remember to clean the area where the fastener is going to be positioned thoroughly before hand to ensure good adhesion. If fitting to a cloth surface ensure the coarse 'hook' half of the fastener is stuck to the bottom of antenna (see diagrams below).

Smooth Hard Surface Fitting

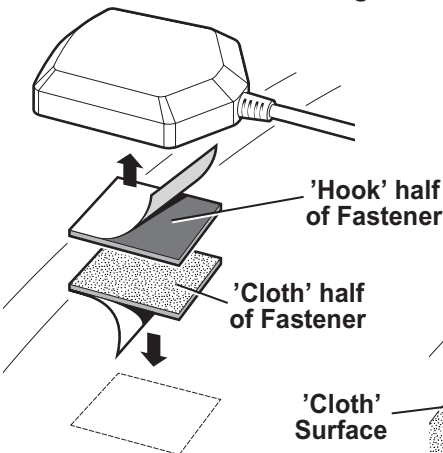

Cloth Surface Fitting

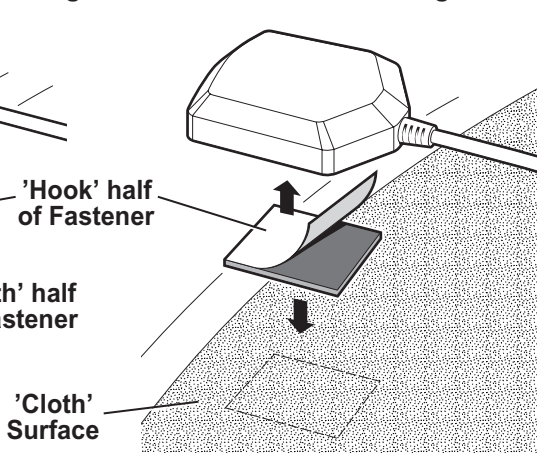

Next feed the cable from the GPS antenna ensuring that it does not interfere with any of the vehicles controls to the position you are going to locate the S6 GPS Control Panel ready for connection.

Installing the S6-GPS Control Panel

Find a suitable position to mount the S6 Control Panel, remembering that you will need to be able to remove it easily for downloading purposes. The unit needs to be situated in a position where you can easily view the LCD display without having to take your eyes too far from the road and so that you can reach the controls safely. You will also need to be sure that you can connect both the power and RLD (If required) connection cables as well as the extension GPS antenna. There are numerous ways of mounting your S6 - On the dashboard using the mounting bracket or hook and loop fastener provided, on the windscreen with the suction-cup bracket provided or by purchasing a custom-fit bracket designed specifically to fit your make and model of vehicle.

Be careful to choose a location that does not block the drivers view or where it might endanger the driver or passengers should your vehicle suddenly come to a stop or be involved in an accident.

1. Using the Hook and Loop Fastener

Your S6 can be installed easily with the hook and loop fastener if you have a sufficiently flat area on your dashboard or centre console.

- Use a damp cloth to thoroughly clean the underside of the GPS control panel and the area where you intend to mount your unit.
- With the two parts of the Hook and Loop fastener still fastened together, peel the backing tape from the softer 'Loop' side of the fastener and apply it to the underside of the GPS control panel.
- Next remove the backing tape from the 'Hook' side of the fastener, again whilst the two parts are still fastened and position the unit onto the desired area. If possible leave the Hook and Loop fastener for 24hrs to adhere properly before using regularly.
- Plug the end of the lead of the GPS antenna already mounted, into the socket marked 'ANTENNA' on the side of the control panel.
- See Page 10 for details of how to connect power to your unit.

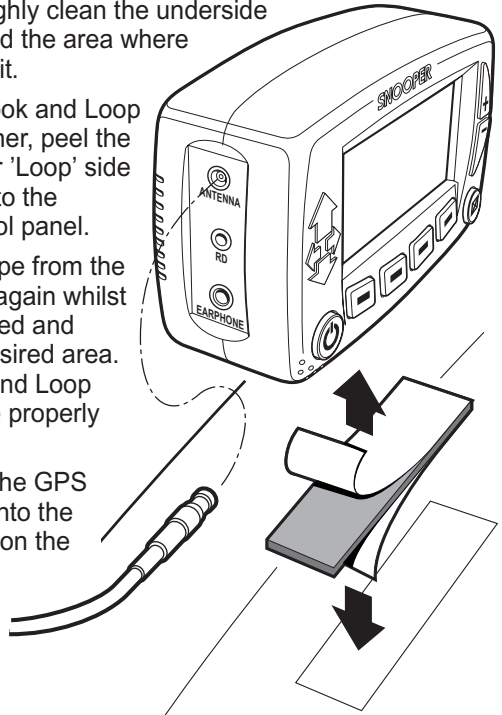

2. Using the Mounting Bracket and Screws

Your S6 can be installed easily with screws if you have a sufficiently flat area on your dashboard or centre console.

- Having decided where to mount your unit, using the mounting bracket as a guide, mark and drill the mounting holes.
- Screw the mounting bracket in place using the screws provided.
- Finally slide the control panel onto the mounting bracket and plug the end of the lead of the GPS antenna already mounted, into the socket marked 'ANTENNA' on the side of the control panel.
- See Page 10 for details of how to connect power to your unit.

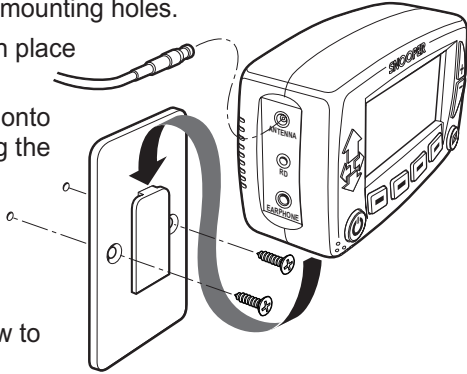

2. Using the Windscreen Suction Cup bracket

If you prefer you can mount the S6 to the inside of your vehicles windscreen using the suction cup bracket provided. Simply select a position within the windscreen remembering that you need to connect both the power and RLD(If required) connection cables as well as the extension GPS antenna.

- Install the suction cups onto the bracket by fitting them into it's holes (A).
- Clean the area where you wish to position the bracket thoroughly with a good quality glass cleaner.
- Carefully bend the bracket so that when it is mounted on to the windscreen with the S6 Control Panel attached, the Control Panel is facing in the desired direction so that you can easily see the LCD display and safely operate the controls.
- Slide the Control Panel onto the bracket until it is secure (B).
- To remove the Control Panel simply slide the unit off the bracket from the front.
- Plug the end of the lead of the GPS antenna already mounted, into the socket marked 'ANTENNA' on the side of the control panel.
- See Page 10 for details of how to connect power to your unit.

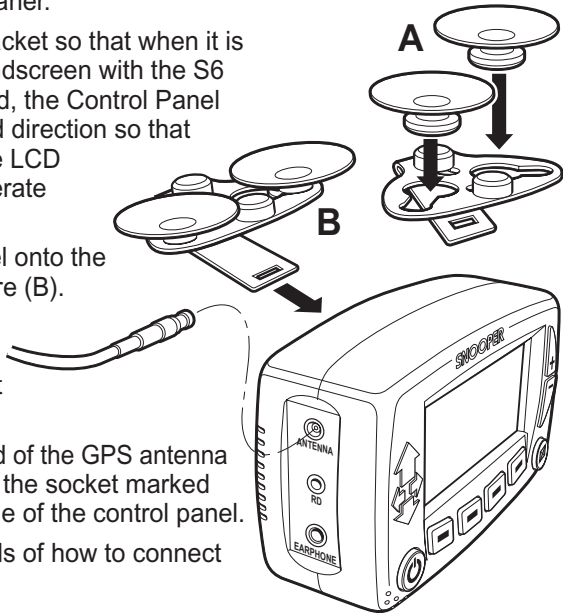

3. S6 Custom fit installation system

It is also possible to purchase a 'Custom fit' mounting bracket for your Snooper S6 GPS control panel. This bracket has been specifically designed for each individual vehicle and is unique in that you do not need to drill any holes in the dashboard or centre console in order to install it in to your vehicle. Depending on the vehicle the bracket either clips to the side of the centre console or even to your vehicles air vents for a convenient trouble free installation. Then simply attach the standard console/dashboard mounting bracket supplied with your S6 to the Custom Fit bracket using the nut and bolt pack provided.

Power Connection

1. Using the cigarette lighter socket

The S6 comes with a power cable designed to plug into your vehicles cigarette lighter socket. Take the lead and plug the smaller end into the DC 12v input socket on the side of the S6 GPS Control Panel and the cigarette lighter adaptor in your vehicles cigarette lighter socket.

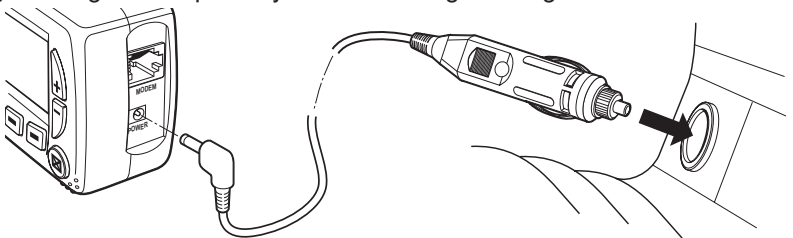

Please Note: Do not leave your S6 plugged into the cigarette lighter socket when you start your vehicle. The cigarette lighter circuit is prone to power surges as the vehicle is started that may damage your unit. If the device does not power up please check that the cigarette lighter socket is clean of any debris, remembering not to insert any metal objects into the socket, check that the cigarette lighter adaptor is inserted all the way into the socket and to check that the fuse in the cigarette lighter adaptor is operational. If your S6 will still not power up, please check that the cigarette lighter in your vehicle is functioning correctly or refer to the Troubleshooting section of this manual.

Replacing the Fuse

If the detector stops operating, the fuse in the cigarette lighter plug might be blown. If it has blown, follow these steps to replace it with a 2 amp, 5 x 20mm, fast acting fuse.

Caution: Using a fuse that does not meet these ratings or defeating fuse protection can damage your detector, the power cable, or the vehicles electrical system.

1. Grasp the ring near the tip of the cigarette lighter plug, then carefully unscrew the ring by turning it counterclockwise.

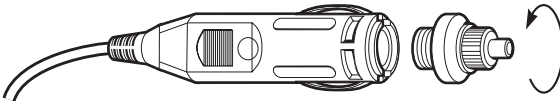

Caution: If you must use pliers to loosen the ring, be careful not to crush the tip. Never use pliers or other tools to retighten the ring on the cigarette lighter plug.

2. Pull the ring straight out, then remove the metal tip, spring and old fuse.

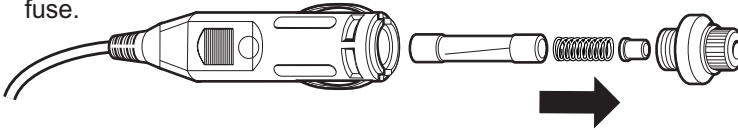

3. Check the fuse to see if it has blown. If it has, replace it.
4. Replace the metal tip and spring inside the ring, then place the fuse inside the cigarette lighter plug and screw the ring back onto the plug. Make sure the metal tip is visible when you reassemble the cigarette lighter plug.

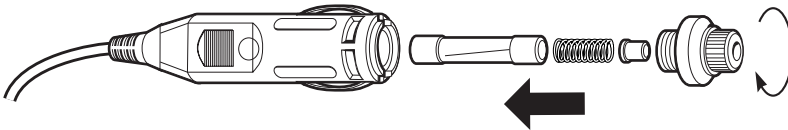

2. Direct connecting/hard wiring your S6 NEO.

You can power your Snooper S6 by wiring it directly to your vehicles 12v electrical system using the 'Hard Wire' cable supplied as standard with your unit. Firstly connect the positive side of the cable (Red) to a 12v switched ignition live. This is a live that is On when the ignition is On and Off when the ignition is Off. The negative side of the lead should be connected to a negative ground, so can be attached to any metal portion of the vehicles frame. Next plug the small adaptor on the other end of the lead into the DC 12v input socket on the side of the unit.

Important: If you are unfamiliar with this procedure, please consult a professional auto electrician

Installation S6-RLD

If you have purchased the S6-R or have purchased the S6-RLD as an optional extra to your S6 you will need to follow the following instructions to install the S6 remote extension radar and laser detector. This device is waterproof so can be installed under the bonnet behind the vehicles grille or within an air intake at the front of your car or you can simply mount the device on the dashboard or windscreen of your vehicle. Please note however that some vehicles including Renault's, Citroen's and Peugeot's may come with a 'Heat reflective' or 'Comfort' front windscreen which may effect the performance of the S6-RLD. In these cases the RLD must be mounted outside the vehicle. For this type of installation follow the instructions for S6-RLD External Installation.

1. Dashboard Mounting

The S6 RLD needs a clear view of the road ahead and needs to be positioned in as horizontal a position as possible. If you can find a position on the dashboard that is fairly flat (Surface must be within 15-20 degrees of the road) and so that the view from the front of the detector is through clear glass and is not obscured by any metallic objects such as the windscreen wipers, the Hook and Loop fastener might provide the easiest method of mounting the detector. To mount the RLD in this way follow these instructions.

- Use a damp cloth to thoroughly clean the bottom of the S6-RLD and the area where you intend to mount the device.
- With the two parts of the Hook and Loop fastener still fastened together, peel the backing tape from the softer 'Loop' side of the fastener and apply it to the bottom of the unit.
- Next remove the backing tape from the 'Hook' side of the fastener, again whilst the two parts are still fastened and position the unit onto the desired area. Please note it will take approximately 24hrs for the Hook and Loop fastener to adhere properly to the dashboard and unit.
- Finally feed the cable from the S6-RLD to the S6 GPS control panel, concealing it as well as possible and plug it into the socket marked 'RD' on the side of the control panel.

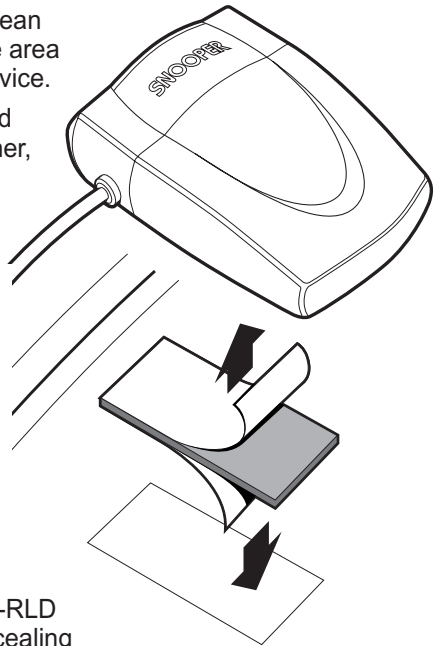

2. Windscreen Mounting

The S6-RLD can also be mounted on the windscreen of your vehicle as long as it not a 'Heat reflective' or 'Comfort' style windscreen sometimes found on newer Renault's, Citroen's and Peugeot's. If you are unsure as to whether your vehicle is fitted with this style of screen please contact your local dealer or call our technical helpline on 0870 787 0700.

The S6-RLD can be mounted anywhere in the windscreen as long as it has an unobstructed view of the road ahead. Follow these instructions to mount the S6-RLD using the suction cup mounting bracket provided.

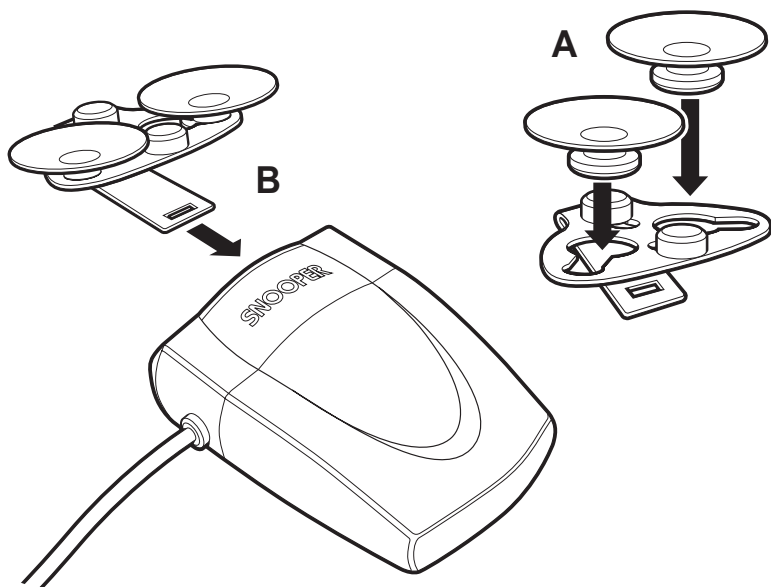

- Install the suction cups onto the bracket by fitting them into the holes (A).
- Find a position on the windscreen to mount the unit, so that the view from the front of the detector is through clear glass and is not obscured by any metallic objects such as the windscreen wipers.
- Clean the area where you wish to position the bracket thoroughly with a good quality glass cleaner.
- Carefully bend the bracket so that when it is mounted on to the windscreen with the S6-RLD attached, the unit is in as horizontal a position as possible.
- Slide the S6-RLD onto the bracket until it is secure (B).
- To remove the S6-RLD simply slide the unit off the bracket from the front.
- Finally feed the cable from the S6-RLD to the S6 GPS control panel, concealing it as well as possible and plug it into the socket marked 'RD' on the side of the control panel.

3. S6-RLD External Installation

As the S6-RLD is waterproof it can be mounted outside the vehicle with the 'L' shaped bracket, water resistant double sided tape and screw pack provided.

- Find a suitable mounting position for the detector, ensuring that the front of the unit has a clear view of the road ahead and is unobstructed by any metallic objects and that there is a sufficient mounting area to attach the 'L' shaped fixing bracket. The S-RLD needs to be mounted in as horizontal a position as possible so that it is looking directly down the road ahead but can be mounted either flat or on it's side if necessary. We recommend that you mount the detector either behind the vehicles grille (If the openings of the grille are at least 10mm in diameter) or within an air intake at the front of the vehicle. The S6-RLD can be mounted anywhere at the front of the vehicle, but for optimum performance we suggest you mount it as close to the the number plate of the vehicle as possible.

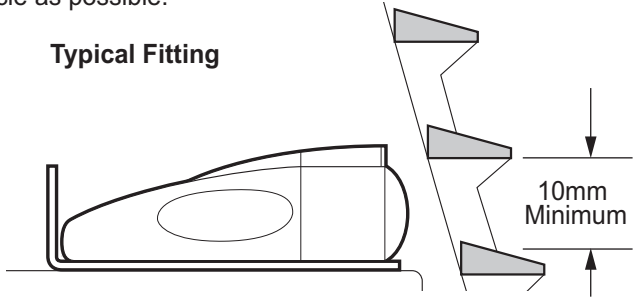

- When you have found a suitable location, using the 'L' shaped mounting bracket as a template, drill between 2 and 4 pilot holes into the selected mounting surface for attaching the bracket using either the self-tapping screws or the nuts and bolts provided. You will need to attach the bracket using at least 2 screws or 2 nuts and bolts to ensure that the bracket is well secured. Remember that there is a lot of vibration within the engine bay so it is very important that S6-RLD mounting bracket is secured correctly.

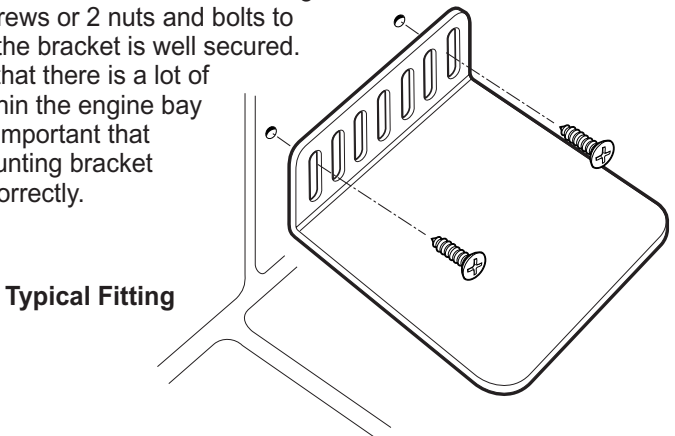

- Next use a damp cloth to thoroughly clean the bottom of the S6-RLD and the side of the bracket where you intend to mount the device.
- Peel the backing paper from one side of the double-sided tape and apply it to the bottom of the unit.

- Next remove the backing paper from the other side of the tape and position the S6-RLD onto the 'L' shaped bracket as indicated in the diagram below ensuring that the front of the detector is facing forwards down the road. Please note it will take approximately 24hrs for the Hook and Loop fastener to adhere properly to the bracket and unit.

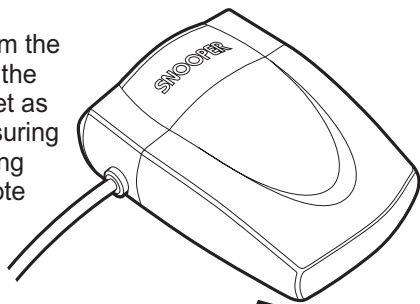

- Feed the cable from the S6-RLD through an existing grommet in the bulkhead to the cockpit of the vehicle and plug the end of the cable into the socket on the side of the S6 GPS control panel marked 'RD'. If there is not a convenient grommet to use you will need to drill an additional hole sealed with a grommet, large enough to feed the cable and plug through. Ensure that the cable running from the S6-RLD to the GPS control panel is secured periodically so that it does not interfere with any of the workings of the vehicle.

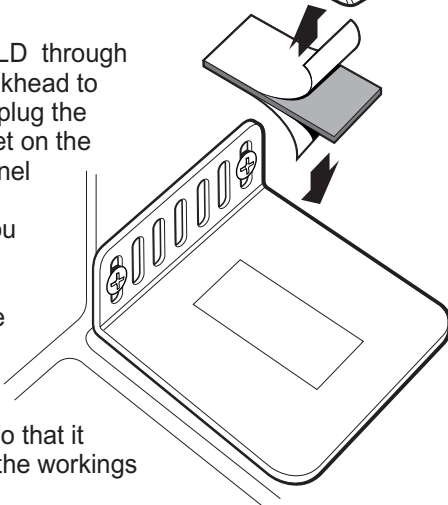

- The S6 control panel will indicate that you have successfully installed the RLD by showing an 'RD' icon on the screen when the unit is powered up.

Mounting Notes

When mounting the S6-RLD always ensure that you mount the unit away from any moving parts such as air cooling fans or the fan belt. Always position the unit so that you can safely feed the cable back through to the cockpit of the vehicle without the cable interfering with any moving parts within the engine bay or interfering with any part of the vehicle that could endanger you or your passengers. Please check that all surfaces are safe to drill through before beginning any work. Important:

If you are unfamiliar with any of the above procedures, please consult a professional auto electrician.

Operating Instructions

1. Starting Up

After you have successfully installed your S6 or S6-R and performed the download it is time to perform the first start up. Firstly make sure your vehicle is parked in as open a space as possible, clear of tall trees and buildings so that the GPS extension antenna has a clear view of the sky above. Next power the unit up by pressing button 1. The LCD display will briefly read 'Snooper' and will then read 'SEARCHING'. The S6 needs to acquire a minimum of 3 satellites to work effectively. Once this has been achieved the S6 will proceed to the standby screen (See Standby Screen next in this section) and the satellite counter on the left hand side of the display will indicate how many satellites your unit can currently see. As soon as the standby screen is being displayed your S6 is ready for use and will now automatically alert you of any locations stored in it's database as well as radar and laser alerts if you have the S6-RLD connected. A variety of Audible and Visual alert patterns are explained later on in this section. See 'Features and Settings' to personalise your unit.



As the GPS engine and antenna have never been used before, the first 'Cold' start up could to take as long as 30mins. Once initialised, subsequent start ups will take as little as 3 mins.

2. Standby Screen

The Standby Screen is the screen you will see when your unit is powered up and successfully installed. It is the display you will see when the unit is not currently detecting or locating a source of radar or laser or a stored co-ordinate.

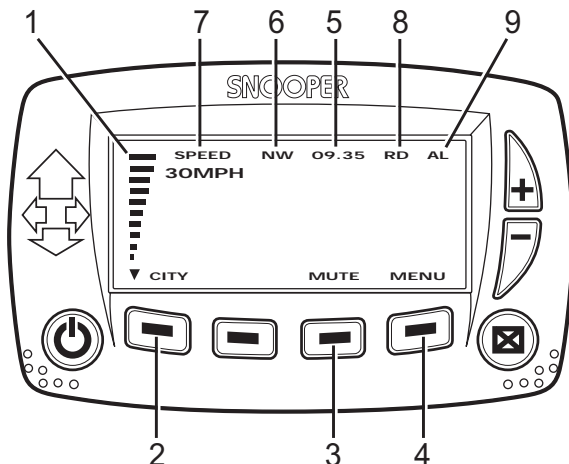

- 1 Satellite Counter - Shows how many satellites your unit can currently see.
- 2 City Button - Use to switch between CITY/MOTORWAY or ALL settings. See page 17 for details.
- 3 Mute Button - Use to cancel audible alert and set AUTOMUTE. See page 21 for details.
- 4 Menu Button - Use to access Full Logic Menu and set features & settings.
- 5 Atomic Clock.
- 6 Indicates direction of travel.
- 7 Shows vehicle speed.
- 8 'RD' icon confirms if your radar/laser detector is successfully connected. (Will only appear if you have S6-RLD).
- 9 CT, MW, AL. Confirms modes 'CITY', 'MOTORWAY' or 'ALL'.

3. City Mode Button

The CITY mode is operated through the CITY button available on the Standby screen and has been designed to help reduce unwanted spurious signals generated by either GPS or Radar and Laser. There are three possible modes to choose from, 'CITY', 'MOTORWAY' or 'ALL'. To change from 'CITY' to 'MOTORWAY' simply press the button below 'CITY' on the display once. The icon will change to 'MW' to confirm your selection. To change from 'MW' to 'ALL' press the button again. The icon will change to 'AL' to confirm your selection. To return to the 'CITY' setting press the button once again. The icon on the display will change to 'CT' to confirm your selection.

CITY MODE

In CITY mode the Snooper S6 will ignore any alert generated through GPS that is actually located on a Motorway that is in range of your device but not an immediate threat to you as you are not actually travelling on that section of road. Important laser and radar alerts remain unaffected.

Please Note that whilst in the CITY mode the device will not detect any locations on Motorways or 'M' roads so you need to remember to switch to either the 'M/WAY' or 'ALL' settings when driving on a Motorway or 'M' road.

MOTORWAY MODE

In M/WAY mode the Snooper S6 will ignore any alert generated through GPS that is actually located on a none Motorway road that is in range of your device but not an immediate threat to you as you are not actually travelling on that section of road. If your speed drops below 20mph the device will sound an audible alert and 'Switch Modes?' will be shown on the display to remind you that you may no longer be travelling on a section of Motorway and may need to change the mode to 'CITY' or 'ALL'. Important laser and radar alerts remain unaffected.

Please Note that whilst in the M/WAY mode the device will not detect any locations on none Motorway roads so you need to remember to switch to either the 'CITY' or 'ALL' settings when leaving an 'M' type road.

ALL MODE

In ALL mode the device will detect all alerts generated through GPS that are within the selected range of the device. If you were travelling on a Motorway for instance it would mean that the unit could detect locations situated on an 'A' road that is near to the Motorway. As it is not on the road you are travelling however it is not a threat and you might prefer to select the Motorway setting so that the unit would ignore unwanted signals located by GPS. Important laser and radar alerts remain unaffected.

4. Cancel Button

If during an alert you decide that you would like to cancel it simply press the 'Cancel' button. The display will automatically return to the Standby screen and the device will be ready to alert you the next time you encounter a stored co-ordinate or radar/laser source.

5. Mute Button

If during an alert you decide that you would like to mute the audible alert, simply press the 'Mute' button. The screen will continue to display a visual alert but no sound will be heard. After you have travelled out of range of the location the device will automatically reset so that next time you encounter a location you will receive both audible and visual alerts as normal.

6. Alert patterns

Gatso & Truvello Safety Cameras

As you approach the Safety Camera the unit will begin to emit your chosen audible alert, either a Soft or Hard 'Beep' at your pre-set alert distance. As you get closer to the camera the 'Beeping' will quicken. At the same time the display will indicate the type of location you are approaching, your current speed, the speed limit at the location, the road number and your distance to the location. If you are approaching a radar based Gatso Camera and have the S6-RLD attached an * will indicate whether the camera is operational or not. This type of alert pattern is the same for Truvello Safety Cameras except that the display would indicate 'Truvello' not 'Gatso' next to the signal strength distance meter.

If you would like to change the alert to a visual alert only press the 'Mute' button to temporarily turn off the sound. If at any time you would like to stop the alert, simply press 'Cancel'

SPECs Safety Camera Systems

Due to the fact that the SPECs camera incorporates a series of cameras that monitor you over a fixed distance, a different alert pattern has been devised to ensure that your concentration is maintained throughout the danger zone. If you are approaching the first camera in

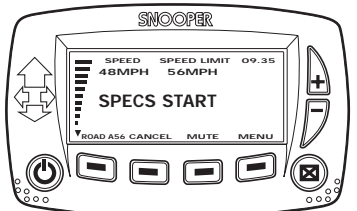
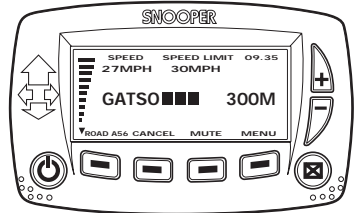

the SPECS system your S6 will begin it's alert at the pre-set alert distance set by you with the display indicating 'SPECS START'. The unit would then emit an audible alert every five seconds to remind you that you are still within the SPECS system. If after 20 seconds you do not pass another camera, for instance if you have turned off the motorway without passing the last camera in the SPECS series, the alert will automatically 'Time out' and the alert will finish.

Whilst travelling through a SPECS series however, your Snooper S6 will provide both an audible and visual alert 250m before each camera as well as indicating the number of each camera in the series i.e. SPECS 2, SPECS 3 and so on, plus continuing to indicate every 5 seconds between locations. When you reach the last camera in the sequence the display will indicate 'SPECS END'

Please note that if you join a road in the middle of a SPECS system you will automatically get a visual and audible alert, indicating the number of that camera in the sequence, 250m before the first camera that you pass. The display will indicate the number of that camera in the overall sequence.

If you would like to change the alert to a visual alert only press the 'Mute' button to temporarily turn off the sound . If at any time you would like to stop the alert, simply press 'Cancel'.

Radar & Laser Alerts

If you have the S6-RLD connected to your S6 you will be able to receive radar & laser alerts. The information provided is more basic than when you receive an alert via GPS but still effective. When the device first receives a radar alert the unit will begin to 'Beep' slowly at first but quicken as you get closer to the source. At the same time the LCD display will indicate what type of radar you are detecting, whilst a signal strength meter in the form of a series of 'Blocks' and a strength 'Level' number will let you know whether you are getting closer to the source or not.

If you receive a laser signal you will get a very similiar alert, however as laser often requires instant action the device simply gives you a full strength audible alert whilst the display will read 'Laser'. No signal strength will be indicated.

As GPS is not used to locate radar or laser only alerts it is impossible to indicate the Speed Limit at these points or the road number.

If you would like to change the alert to a visual alert only press the 'Mute' button to temporarily turn off the sound. If at any time you would like to stop the alert, simply press 'Cancel'

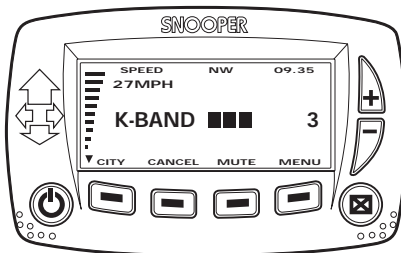

4. Saving new co-ordinates

If in the unlikely event that you pass the location of a Safety Camera and your Snooper S6 does not provide an alert, the S6 gives you the opportunity to upload the co-ordinates of the location manually. Simply park safely as close as possible to the site and press the new location button. An icon will appear on the display to confirm that the location has been saved successfully. Next time you perform a download you will get the opportunity to upload the new site for verification. If verified successfully the co-ordinates will be added to our master database.

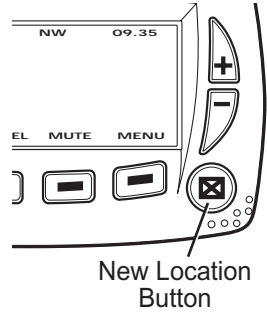

If during the period before you perform your next download, you pass the site again your S6 will now alert you to the new location. As the device does not know what type of system you are passing the display will describe it simply as 'MEMO' and the number of that co-ordinate in the units memory.

Features & Settings

1.Alert Settings

The Alert Settings allows you to adjust the distance that your S6 will detect from when utilising GPS and also allows you to set the type of audible warning you hear as the device alerts you to a location. To enter 'ALERT SETTINGS' from the Standby screen press the button below 'Menu' (5) on the LCD display and then using the buttons below the Up (3) and Down (4) arrows on the LCD display, scroll until the screen reads 'ALERT SETTINGS' Then simply press the button below 'Select' (5) on the display and again use the buttons below the arrows on the display to highlight the setting, either 'AUDIBLE ALERT' or 'SET PRE ALERT' depending on what you would like to adjust. Once you have made your choice press the 'Select' button.

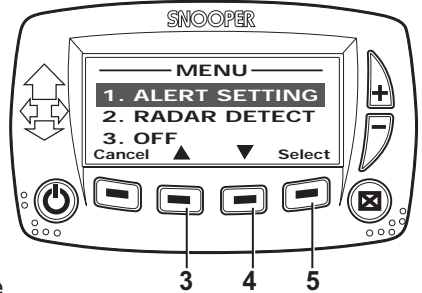

AUDIBLE ALERT - There are three AUDIBLE ALERTS to choose from, using the buttons below the arrows on the display (3 & 4), choose between HARD TONE, SOFT TONE and OFF for no audible alert and press the 'Select' button (5) to confirm your selection. The display will read 'SETTING CONFIRMED' and will return to the Standby screen.

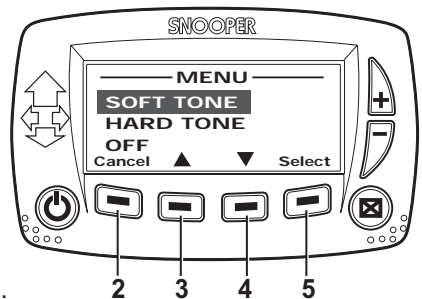

To return to the previous screen, press the button below 'Back' (2) on the display once. If you have finished in any part of the Menu or want to return to the Standby screen, press and hold the 'Back' button for 2 seconds. If no buttons are pressed on the device for a period of 5 seconds the screen will automatically return to the Standby display.

SET PRE-ALERT - After selecting 'SET PRE ALERT' using the instructions above, the display will read 'DISTANCE' with either the factory default warning distance or your previous selection. To increase the distance that your S6 detects from press the button below the Up arrow (3) until the distance you require is shown on the display. To decrease the distance that your S6 detects from, press the Down button (4) until the distance you require is shown in the display. Once you have made your selection press the 'Select' button (5). The display will read 'SETTING CONFIRMED' to confirm your selection and will return to the Standby screen.

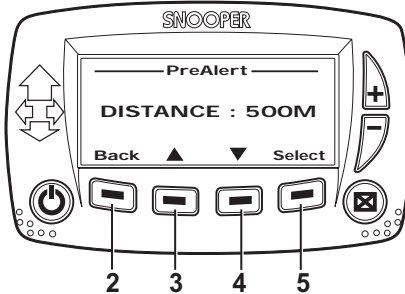

To return to the previous screen, press the button below 'Back' (2) on the display once. If you have finished in any part of the Menu or want to return to the Standby screen, press and hold the 'Back' button for 2 seconds. If no buttons are pressed on the device for a period of 5 seconds the screen will automatically return to the Standby display.

2. Radar/Laser detector settings - S6-RLD only.

This setting is only applicable if you have purchased the S6-R or the S6-RLD as an optional extra and allows you to turn the RLD Off in low risk situations and choose between receiving both Radar and Laser alerts or Laser only.

From the Standby screen press the button below 'Menu' on the LCD display and then using the buttons below the Up (3) and Down (4) arrows on the LCD display, scroll until the screen reads 'RADAR DETECTOR'. Then simply press the button below 'Select' (5) on the display and again using the buttons below the arrows on the display, highlight your desired setting, choosing either 'RADAR & LASER', 'LASER ONLY' or 'OFF'. Once you have made your choice press the 'Select' button. The screen will read 'SETTING CONFIRMED' to confirm your selection and will return to the Standby screen.

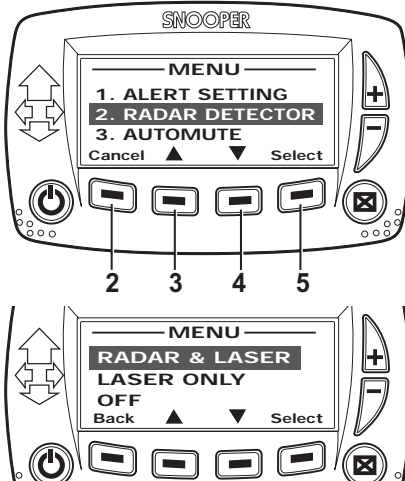

To return to the previous screen, press the button below 'Back' (2) on the display once. If you have finished in any part of the Menu or want to return to the Standby screen, press and hold the 'Back' button for 2 seconds. If no buttons are pressed on the device for a period of 5 seconds the screen will automatically return to the Standby display.

3. Automute

The Automute setting offers the user an alternative audible alert. If Automute is selected, when your device detects a signal, rather than continually beeping through the alert, it simply beeps a small number of times, depending on the strength of the signal and will then only emit a low volume 'clicking' sound until you are out of range of the source. This allows you to receive a brief audible alert instead of a continuous one. To select or de-select the Automute please follow the following instructions.

From the Standby screen press the button below 'Menu' on the LCD display and then using the buttons below the Up (3) and Down (4) arrows on the LCD display, scroll until the screen reads 'AUTOMUTE' and press the button below 'Select' (5) on the display. Then using the buttons below the arrows on the display, highlight your desired setting, either 'On' or 'Off'. Once you have made your choice press the 'Select' button. The screen will read 'SETTING CONFIRMED' to confirm your selection and will return to the Standby screen.

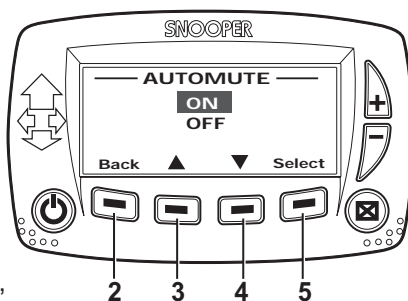

To return to the previous screen, press the button below 'Back' (2) on the display once. If you have finished in any part of the Menu or want to return to the Standby screen, press and hold the 'Back' button for 2 seconds. If no buttons are pressed on the device for a period of 5 seconds the screen will automatically return to the Standby display.

4. Speed Limit Alert

This safety feature has been designed to let you programme your S6 to alert you when you reach any speed you choose. For instance you could set your S6 to alert you when your speed reaches 30mph so that you never accidentally stray over the speed limit. To set the Speed Limit Alert please follow the following instructions.

From the Standby screen press the button below 'Menu' on the LCD display and then using the buttons below the Up (3) and Down (4) arrows on the LCD display, scroll until the screen reads 'SPEED LIMIT ALERT'

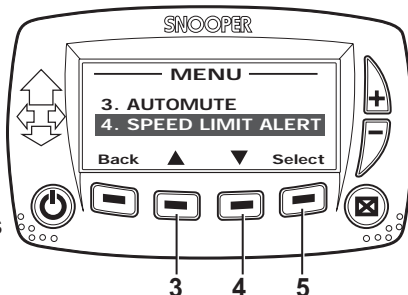

and press the button below 'Select' (5).

Then using the buttons below the arrows on the display, highlight your desired setting, either 'ON' or 'OFF'.

Once you have made your choice press the 'Select' button. If you are turning the setting 'ON' the screen will then either display a factory default speed or your previous speed selection, use the arrows to increase or

decrease the speed to your desired setting and press 'Select'. The screen will read 'SETTING CONFIRMED' to confirm your selection and will return to the Standby screen.

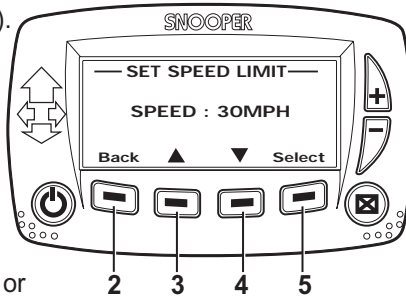

To return to the previous screen, press the button below 'Back' (2) on the display once. If you have finished in any part of the Menu or want to return to the Standby screen, press and hold the 'Back' button for 2 seconds. If no buttons are pressed on the device for a period of 5 seconds the screen will automatically return to the Standby display.

Please note that there could be a satellite delay of one or two seconds so that the speed reading generated by the device may be different to your actual speed. Always check your speedometer for confirmation of your vehicles speed.

5. Speed measurement type

This feature allows you to select between mph and kmh. The device comes with mph turned On as the factory default setting. To change this setting please follow the following instructions.

From the Standby screen press the button below 'Menu' on the LCD display and then using the buttons below the Up (3) and Down (4) arrows on the LCD display, scroll until the screen reads 'SPEED MEASUREMENT TYPE' and press 'Select' (5). Then using the buttons below the arrows on the display, highlight your desired setting,

either 'MPH' or 'KMH'. Once you have made your choice press the 'Select' button. The screen will read 'SETTING CONFIRMED' to confirm your selection and will return to the Standby screen.

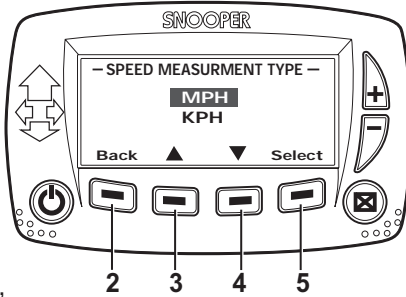

To return to the previous screen, press the button below 'Back' (2) on the display once. If you have finished in any part of the Menu or want to return to the Standby screen, press and hold the 'Back' button for 2 seconds. If no buttons are pressed on the device for a period of 5 seconds the screen will automatically return to the Standby display.

6. Vehicle speed

This is a selectable feature that gives you the choice of having your vehicles speed displayed constantly on the screen of your S6. Your S6 comes with this option turned On as the factory default setting. To change this setting please follow the following instructions.

From the Standby screen press the button below 'Menu' on the LCD display and then using the buttons below the Up and Down arrows on the LCD display, scroll until the screen reads 'SHOW VEHICLE SPEED' and press 'Select'. Then using the buttons below the arrows on the display, highlight your desired setting, either 'ON' or 'OFF'. Once you have made your choice press the 'Select' button. The screen will read 'SETTING CONFIRMED' to confirm your selection and will return to the Standby screen.

To return to the previous screen, press the button below 'Back' on the display once. If you have finished in any part of the Menu or want to return to the Standby screen, press and hold the 'Back' button for 2 seconds. If no buttons are pressed on the device for a period of 5 seconds the screen will automatically return to the Standby display.

Please note that there could be a satellite delay of one or two seconds so that the speed reading generated by the device may be different to your actual speed. Always check your speedometer for confirmation of your vehicles speed.

7. Camera detection settings

There are a number of different ways that you can programme your S6 to locate 'fixed' cameras such as Gatso cameras and Truvello cameras. You can choose between three different Logic Modes and have the option of Smart Mute. The following information describes the specification of each different option.

Logic Mode 1 (Factory default setting) - If you select Logic Mode 1, your S6 will give you your chosen Soft or Hard tone Audible alert as well as Visual alerts of Gatso and Truvello cameras on both sides of the road. If you encounter a series of SPECs cameras the S6 has been designed to only ever detect systems on your side of the carriageway.

Logic Mode 2 - If you select Logic Mode 2, your S6 will give you your chosen Soft or Hard tone Audible alert as well as Visual alerts of Gatso and Truvello cameras on your side of the road but will only give you a Visual alert of lower risk cameras that are monitoring vehicles coming towards you on the other side of the carriageway. The S6 will still only alert you to SPECs systems that are on your side of the road.

Logic Mode 3 - If you select Logic Mode 3, your S6 will give you your chosen Soft or Hard tone Audible alert as well as Visual alerts of Gatso and Truvello cameras on your side of the road but will only give you a Soft Tone Audible Alert and a Visual alert of lower risk cameras that are monitoring vehicles coming towards you on the other side of the carriageway. The S6 will still only alert you to SPECs systems that are on your side of the road.

To change the Logic Mode setting follow these instructions.

From the Standby screen press the button below 'Menu' on the LCD display and then using the buttons below the Up (3) and Down (4) arrows on the screen, scroll until the display reads 'SAFETY CAMERAS' and press 'Select' (5). Then using the buttons below the arrows on the display, highlight the features you would like to set, either 'SET LOGIC MODE' or 'SET SMART MUTE' and press 'Select'. Next highlight your preferred Logic Mode by again using the up or down arrows. Once you have made your choice press the 'Select' button. The screen will read 'SETTING CONFIRMED' to confirm your selection and will return to the Standby screen.

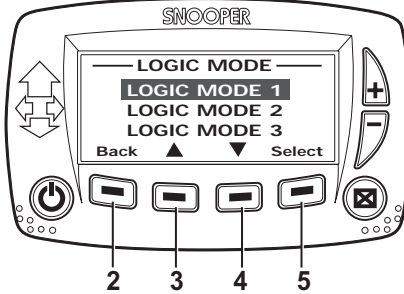
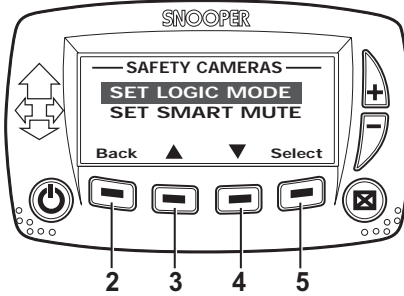

To return to the previous screen, press the button below 'Back' (2) on the display once. If you have finished in any part of the Menu or want to return to the Standby screen, press and hold the 'Back' button for 2 seconds. If no buttons are pressed on the device for a period of 5 seconds the screen will automatically return to the Standby display.

Smart Mute - The Smart Mute setting has been designed so that you only receive Visual alerts generated by the S6 GPS control panel if you are travelling below the posted speed limit as you approach a given location such as a Gatso camera. If you are travelling above the posted speed limit you would receive both a Visual as well as an Audible alert as normal. The Smart Mute setting also activates a radar/laser filter designed to filter out any radar/laser signals you should encounter whilst travelling below 27mph.

To activate the Smart Mute setting follow these instructions.

From the Standby screen press the button below 'Menu' on the LCD display and then using the buttons below the Up (3) and Down (4) arrows on the screen, scroll until the display reads 'Safety Cameras' and press 'Select' (5). Then using the buttons below the arrows on the display, highlight the features you would like to set, either 'SET LOGIC MODE' or 'SET SMART MUTE' and press 'Select'. Then, again use the up or down arrows to highlight your desired setting, either 'ON' or 'OFF'. Once you

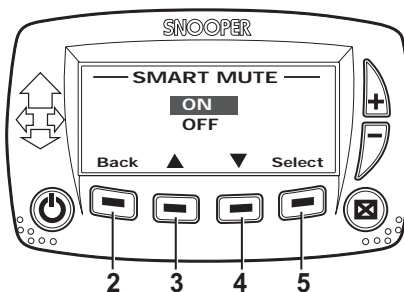

have made your choice press the 'Select' button. The screen will read 'Setting Confirmed' to confirm your selection and will return to the Standby screen.

To return to the previous screen, press the button below 'Back' (2) on the display once. If you have finished in any part of the Menu or want to return to the Standby screen, press and hold the 'Back' button for 2 seconds. If no buttons are pressed on the device for a period of 5 seconds the screen will automatically return to the Standby display.

8. Atomic Clock

This is a selectable feature that allows you to have the time shown on the display of your S6 provided by the GPS Atomic Clock. The time on this clock is generated directly from GMT and is completely accurate. The S6 comes with this feature turned On as the factory default setting.

To activate or de-activate the Atomic Clock follow these instructions.

From the Standby screen press the button below 'Menu' on the LCD display and then using the buttons below the Up and Down arrows on the LCD display, scroll until the screen reads 'Atomic Clock' and press 'Select'. Then using the buttons below the arrows on the display, highlight your desired setting, either 'ON' or 'OFF'. Once you have made your choice press the 'Select' button. If you select 'ON' the device will give you the option to select British Summer Time (BST) or Greenwich Mean Time (GMT). Using buttons 3 or 4 choose your desired setting and press 'Select'. The screen will read 'SETTING CONFIRMED' to confirm your selection and will return to the Standby display.

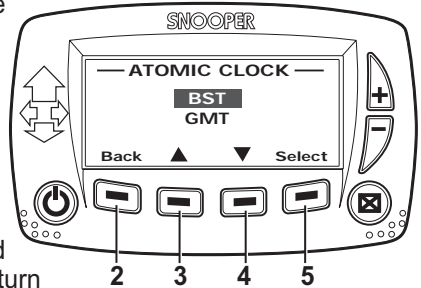

To return to the previous screen, press the button below 'Back' (D) on the display once. If you have finished in any part of the Menu or want to return to the Standby screen, press and hold the 'Back' button for 2 seconds. If no buttons are pressed on the device for a period of 5 seconds the screen will automatically return to the Standby display.

9. Setting the LCD backlight alert

The LCD display on the Snooper S6 has a backlight so that at night or in dark conditions you will still be able to clearly read the information on the display. The backlight has three variable settings you can choose from. The S6 can be programmed so that the the backlight is permanently Off or permanently On when the unit is powered up or you can programme the Backlight to come On only during an alert (This is the factory default setting)

To set the LCD backlight alert please follow these instructions.

From the Standby screen press the button below 'Menu' on the LCD display and then using the buttons below the Up (3) and Down (4) arrows on the LCD screen, scroll until the display reads 'Backlight' and press 'Select' (5). Then using the buttons below the arrows on the display, highlight your desired setting, either 'ON', 'OFF' or 'ONLY ON ALERT'.

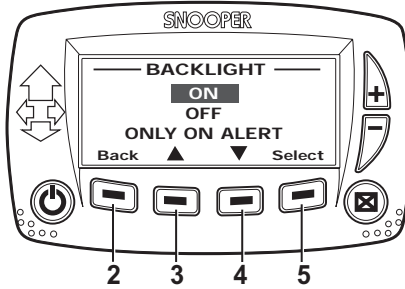

Once you have made your choice press the 'Select' button. The screen will read 'SETTING CONFIRMED' to confirm your selection and will return to the Standby screen.

To return to the previous screen, press the button below 'Back' (2) on the display once. If you have finished in any part of the Menu or want to return to the Standby screen, press and hold the 'Back' button for 2 seconds. If no buttons are pressed on the device for a period of 5 seconds the screen will automatically return to the Standby display.

10. Compass

This is a selectable feature that allows you to have your direction of travel shown on the display of your S6 at all times. The display will show either N, NE, W, SW, S, SE, E, NE. The Snooper S6 comes with the compass feature turned On as the factory default setting.

To activate or de-activate the Compass setting follow these instructions.

From the Standby screen press the button below 'Menu' on the LCD display and then using the buttons below the Up and Down arrows on the LCD display, scroll until the screen reads 'COMPASS' and press 'Select'. Then using the buttons below the arrows on the display, highlight your desired setting, either 'ON' or 'OFF'. Once you have made your choice press the 'Select' button. The screen will read 'SETTING CONFIRMED' to confirm your selection and will return to the Standby screen.

To return to the previous screen, press the button below 'Back' on the display once. If you have finished in any part of the Menu or want to return to the Standby screen, press and hold the 'Back' button for 2 seconds. If no buttons are pressed on the device for a period of 5 seconds the screen will automatically return to the Standby display.

11. Satellite Counter

This is a selectable feature that allows you to have the number of satellites that the S6 can currently see shown on the display of your S6 at all times. The Snooper S6 comes with the Satellite Counter feature turned On as the factory default setting.

To activate or de-activate the Satellite Counter setting follow these instructions.

From the Standby screen press the button below 'Menu' on the LCD display and then using the buttons below the Up and Down arrows on the LCD display, scroll until the screen reads 'SATELITT COUNTER' and press 'Select'. Then using the buttons below the arrows on the display, highlight your desired setting, either 'ON' or 'OFF'. Once you have made your choice press the 'Select' button. The screen will read 'SETTING CONFIRMED' to confirm your selection and will return to the Standby screen.

To return to the previous screen, press the button below 'Back' on the display once. If you have finished in any part of the Menu or want to return to the Standby screen, press and hold the 'Back' button for 2 seconds. If no buttons are pressed on the device for a period of 5 seconds the screen will automatically return to the Standby display.

12. Adjusting the volume

The S6 has an adjustable volume for controlling the loudness of the audible alert. To increase the volume simply press and hold button 8 on the control panel. To decrease the volume press and hold button 7. The display will give you a visual confirmation of the volume set.

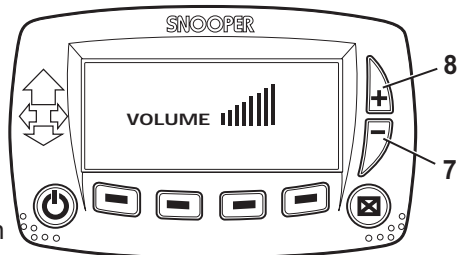

13. Adding and deleting new locations

It is possible to add and edit your own personal locations on your Snooper S6 GPS control panel. To add a new location simply press the 'New Location' (6) button on the device whilst you are at the location you have chosen to select. To view your saved co-ordinates press the 'Menu' button and using the buttons below the arrow icons (3 & 4) scroll up or down until the screen reads 'MEM edit' and press 'Select'. Any co-ordinates stored will be listed in numerical order - MEM01, MEM02, MEM03 etc. These co-ordinates can be uploaded for verification if necessary (See 'Uploading' page 6). If you wish to delete any co-ordinates simply use the up or down buttons to highlight the location you would like to look at and press the 'Select' button (5). You can save up to 99 personal locations in total.

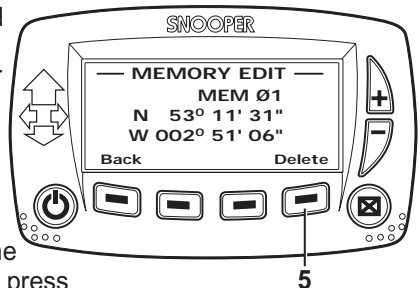
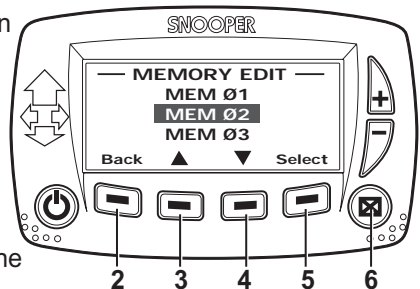

14. Dial-up numbers

If you want to perform a download from within an office or hotel the unit may need to dial '9' first to obtain a tone. Equally if you wish to perform a download from outside of the UK the unit will need to dial '0044' to make a connection, As a result you will need to change the device settings in either of these situations, by following these instructions.

From the Standby screen press the 'Menu' button on the LCD display and then using the Up (3) or Down (4) buttons, scroll until the screen reads 'EDIT TEL. NUMBER' and press the 'Select' (5) button. Again using the Up or Down buttons highlight your desired settings, choosing either 'STANDARD' for normal dial-ups from within the UK, 'INTERNATIONAL' for dial-ups from outside the UK, or 'EXTERNAL LINE' if you need to dial '9' to obtain an outside line from an office or hotel.

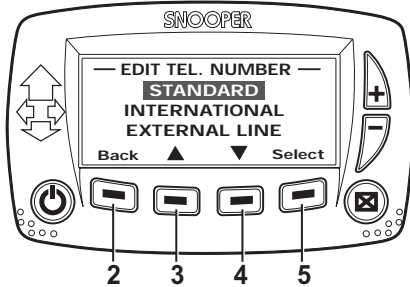

Once you have made your choice press the 'Select' button. The screen will read 'SETTING CONFIRMED' to confirm your selection and will return to the Standby screen.

To return to the previous screen, press the button below 'Back' on the display once. If you have finished in any part of the Menu or want to return to the Standby screen, press and hold the 'Back' button for 2 seconds. If no buttons are pressed on the device for a period of 5 seconds the screen will automatically return to the Standby display.

Motorcycle installation

The Snooper S6 and S6-R can both be installed on to your motorcycle. An ear-piece is available as an optional extra so that audible alerts can be heard.

Instructions for mounting the S6 and S6-R are as per the installation guide on pages (?) - (?). Remember however that the S6 GPS control panel is not waterproof so needs to be mounted within a tank bag or other waterproof holder. Always remember that for your S6 or S6-R to work effectively that the GPS antenna has an open, clear view of the sky and that if you are installing the S6-RLD it has a clear view of the road ahead, unobstructed by metallic objects. If you require any further advice on installation please contact our technical help line on 0870 780 0700.

Troubleshooting

The unit cannot be switched on.

Check that the cigarette lighter adaptor is well inserted into the cigarette lighter socket and that the cigarette light socket is functioning properly. Check that the lighter socket is clean and free from debris. Also check that the fuse in the cigarette lighter adaptor is functioning correctly.

If you are using the hardwire connection check that you have secured a good earth and that you have taken the 12v feed from a 12v supply that is live on ignition. Also check that the in-line fuse is operating correctly.

The unit cannot acquire satellites.

Check that the extension GPS antenna has a clear view of the sky and that it is plugged properly into the correct socket on the side of the S6 GPS control panel.

If this is the first time you have powered up your Snooper S6 please remember that the first 'cold' start may take as long as 30 minutes to acquire sufficient satellites for operation.

Disconnect and re-connect the power to the unit and start the power up procedure again.

Check that your vehicle does not have a 'heat reflective' or 'comfort' style front windscreen. If it has re-position the GPS Extension Antenna to the rear window.

The satellite signal temporarily or permanently drops out.

This may happen temporarily in areas where there are a significant number of tall buildings or trees or whilst driving through a tunnel. The signal should only be lost for a few seconds and quickly reacquired.

Check that the extension GPS has not moved and still has a good clear view of the sky above.

Very occasionally you may experience bad satellite coverage that may lead to you losing a signal. This should last no longer than a few short minutes.

The device does not appear to respond to Police speed monitoring systems

Have you performed a download recently? If not perform a fresh download to ensure that you have all the latest co-ordinates stored on your device.

If you have the S6-RLD installed check that it is positioned in such a way that the antenna lens is facing forwards and that it has a clear view of the road and is unobstructed by any metallic objects.

Check your settings to see if you have 'Smart Mute' activated. If 'Smart Mute' has been activated the device will only alert to GPS generated locations if you are travelling above the posted speed limit and detect radar and laser sources if you are travelling above 27 mph.

SPECIFICATION

Dimensions

S6 GPS Control Panel.....H72mm x W114mm x D46mm
GPS Extension Antenna.....H13mm x W40mm x D48mm
S6-RLD Radar/laser detector.. H39mm x W77mm x D104mm

RADAR

Receiver typeDual Conversion Super heterodyne
Antenna type Linear Polarized, Self-Contained Antenna
Detector type Scanning Frequency Discriminator
Eurotech 2000 Frequencies

LASER

Receiver type Pulsed Laser Signal Receiver
Detector type Digital Signal Processed Pulse
Width Discriminator
Opto sensor High Speed Photo Diode Detector
Spectral Response 800 ~ 1,100nm

GPS

Receiving method 18 channels parallel
Receiving frequency 1575.42MHz +/- 1MHz, C/A code
Cold start 50 sec(Typ.) At normal temperature
Warm start 45 sec(Typ.) At normal temperature
Hot start 20 sec(Typ.) At normal temperature
Power requirement +3.1VDC ~ +3.6VDC
Current Consumption 110 ~ 156mA

Snooper Accessories & Price list

The following accessories are available from your local Snooper dealer.
For further details please contact our technical helpline on

S6-RLD - Remote extension radar/laser detector.....	£149.95
Remote GPS extension antenna.....	£34.95
Coiled power lead with cigarette lighter adaptor.....	£12.95
2m Straight power lead with cigarette lighter adaptor.....	£12.95
2m Straight hard wire lead.....	£12.95
Windscreen mounting bracket.....	£12.95
Console/dashboard mounting bracket.....	£7.95
Hook & loop fastener.....	£2.95
Telephone socket connection cable.....	£12.95
1-3 Lighter socket extension.....	£7.95
25ml anti-static LCD display cleaner & protector.....	£7.95
12v power supply.....	£12.95
Under bonnet RLD mounting bracket.....	£12.95
RLD 3m extension cable.....	£12.95
RLD double sided fixing tape.....	£2.95
EAR-PIECE for Motorcycle use.....	£19.95
Custom fit console/dashboard mounting bracket.....	£POA

(This bracket is designed specifically to fit each individual vehicle.
Therefore you will need to quote the make, model and year of your
vehicle at the time of ordering)

Service Under Warranty

1 To obtain service during the two year warranty period, return your detector, postage paid by recorded delivery and in suitable packaging to:

**Performance Products Limited
Clever House
Sarus Court
Manor Park
Runcorn
WA7 1UL**

Tel: +44 (0)870 78 70 700

Fax: +44 (0)870 78 71 700

2 Enclose the following information:

- (a) Your name, return address and description of the problem.
- (b) A telephone number where you can be reached during business hours.
- (c) Proof of purchase.

SERVICE UNDER WARRANTY

Registering your Snooper S6 or S6-R neo

The database built into your Snooper S6 or S6-R is unpopulated when purchased for security reasons. As a result you must register your unit before you are able to complete any downloads. There are four ways of registering your unit as follows:-

Register On-Line

Go to the official Snooper S6 website - www.s6neo.co.uk and register On-Line and take advantage of our On-Line registering discount scheme. Your unit should be activated within 15 minutes of registration.

By Telephone

Contact us by telephone 7 days a week between the hours of 9.30am and 4.30pm. Tel: 0870 780 0700. Your unit should be activated within 1 hour of registration.

By Fax or Post

Fill out the registration form included with your S6 or S6-R neo and fax it to 0870 78 71 700. Your unit should be activated within 1 hour of registration. If you would like to register by post send the completed form to us at :-

**Performance Products Ltd,
Cleaver House, Sarus Court,
Manor Park, Runcorn. WA7 1UL**

If you register by post your unit should be activated within 24 hours of our receipt of your completed registration form.

Please ensure that you have the Serial Number of your unit and a method of payment to hand before contacting us.